

Grille anti-vélo

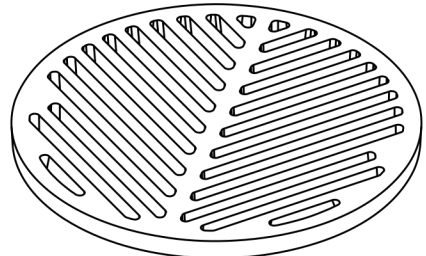

Grille anti-vélo # 610-5351

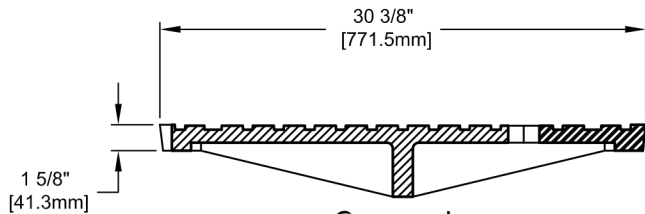

Couvercle

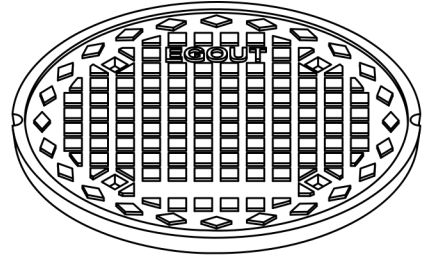

Couvercle # 610-5346

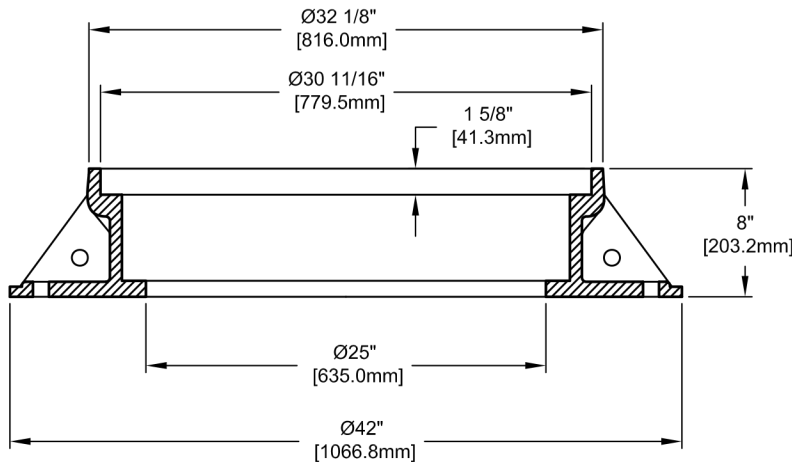

Cadre

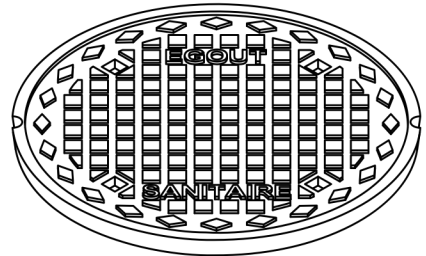

Couvercle # 610-5331

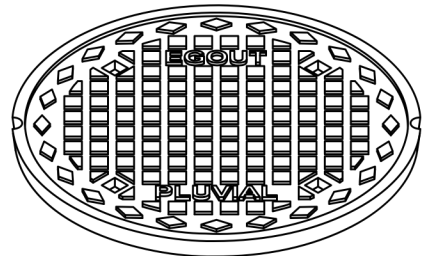

Couvercle # 610-5341

**SPÉCIFICATIONS:**

Matériau: Cadre, Couvercle et Grille: Fonte grise classe 30

Certification Produit: Certifié 2078  BNQ 3221-500  
Conforme ASTM A536.65-45-12

Couvercle: Inscripton,  
Grille anti-vélo # 610-5351 (non certifié BNQ)  
Sanitaire # 610-5331  
Pluvial # 610-5341  
Égout # 610-5346

Poids: Cadre: 380 Lbs  
Couvercle: 270 Lbs  
Grille: 190 Lbs

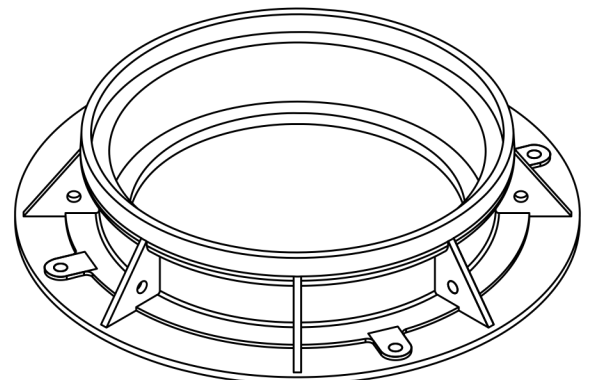

Cadre # 610-5321



19 Place Triaucourt  
Lorraine (Québec)  
J6Z 4K2  
Tél.: 450.621.3177  
1.888.621.3177  
Fax.: 450.621.0167

**CADRE ET COUVERCLES  
PED 402**